

**Technical Specification  
of  
Ground Based Pole of 20, 22 & 24m height  
(Including Foundation, Earthing System & Aviation Warning Lamp)**

**Specification No.: UTL/GBP/02-01 OCT 2011**



**United Telecom Limited**  
(JV of MTNL, TCIL, TCL & NVPL)  
Triveni Complex, Putali Sadak, Kathmandu, Nepal

**Price: NRs. 1130  
(Including VAT)**

**Technical Specification  
of  
Ground Based Pole of 20, 22 & 24m height  
(Including Foundation, Earthing System & Aviation Warning Lamp)**

**Specification No.: UTL/GBP/02-01 OCT 2011**



**United Telecom Limited**  
(JV of MTNL, TCIL, TCL & NVPL)  
Triveni Complex, Putali Sadak, Kathmandu, Nepal

## Table of Contents

Chapter	Title	Page
1.	General Specifications	4
2.	Bill of Materials Of Towers & Foundation	10
3.	Earthing System & Lightning Arrestor	25
4.	Aviation Warning Lamp	28
5.	Key Diagrams	29

## **Chapter-1**

### **General Specifications**

#### **1.0 Introduction**

This document contains the generic requirements of self supporting type 24, 22 & 20m Ground Based Pole for Cellular wireless systems etc. The poles shall be able to support the loading of the antennas as given below:

- a. 1 Nos. of 1.2m diameter Solid antenna at 3.0m from the Top.
- b. 2 Nos. of 0.6m diameter Solid Antenna at 1.5m from the Top.
- c. 6 Nos. of panel antennas for cellular wireless systems (2600X262X115) weighing 50Kg, at 1m from the top.

#### **1.1 Other parameter for designing of poles shall be as under**

- a. Factor of Safety = 1.5
- b. Basic Wind Speed = 180 Km/hr
- c. Terrain Category = 2
- d. Tower twist and sway is found to be less than 0.5 deg @ 75% of basic wind speed.

#### **2.0 Detailed Technical Requirements**

##### **2.1 Type of Pole**

Ground Based Pole type.

##### **2.2 Foundation**

The foundation design/drawings of poles, given in the specifications UTL/GBP/01-01 OCT 2011 and UTL/GBP/02-01 OCT 2011 may be considered for reference and actual foundation design/drawing shall be as per the actual site requirements.

The foundation reinforcement details for soft soil is given in Chapter-2.

**Material:** M-20 grade concrete shall be used. High yield strength deformed steel bars of grade FE-415 conforming to IS: 1786 (1985) shall be used. Bending of bars shall be as per IS: 2502 (1963).

Non-galvanizing steel structures such as Anchor bolts etc. should be painted with red oxide coating. The base plates shall be galvanized as some portion of them may be directly exposed to environment.

## **2.3 Super Structure**

### **2.3.1 Legs/ Bracings**

**Material:** MS angles of grade 'A' as per IS 2062, IS: 808 (1989) shall be used.

**Finish:** All MS angles are to be hot dip galvanized as per IS: 4759 (1996). Zinc for galvanizing should conform to IS: 13229- 1991 or IS: 209 (1992).

### **2.3.2 Gusset/ Splice Plates/ Flange plates**

**Material:** MS Plates of grade 'A' as per IS 2062 shall be used.

**Finish:** All the plates are to be hot dip galvanized as per IS: 4759 (1996). Zinc for galvanizing should conform to IS: 13229- 1991 or IS: 209 (1992).

### **2.3.3 Pole tube**

**Material:** MS Plates, for making pole, tube, shall be grade 'B' as per IS 2062 shall be used.

**Length:** The length of each segment shall not be more than 2m. Each segment shall be made of single plate.

**Finish:** All the plates are to be hot dip galvanized as per IS: 4759 (1996). Zinc for galvanizing should conform to IS: 13229- 1991 or IS: 209 (1992).

### **2.3.4 Nuts, Bolts & Washers**

**Material:** Nuts and bolts of grade 5.6 as per IS: 6639 (1972), IS: 1364, IS: 1367 part 8 (1992) ad plain washers as per IS: 6610 (1972) & spring washers of type 'B' as per IS: 3063 (1994) shall be used.

**Finish:** Nuts, bolts and Washers are to be hot dip galvanized as per IS: 1367.

## **2.4 Arrangement for feeder cable rack/bracket**

Rack/ bracket for running feeder cable(s)/ waveguide(s) from the rear of the antennas up to the Base Transceiver (BTS) equipment shall be provided. Suitable supports shall provide for all the feeder cable runs at 800 mm each. Width of each rack/bracket will be 350mm.

## **3.0 Step Bolt**

A step bolt shall be provided with appropriate cleat welded on pole at 300mm spacing alternately for the height up to 2m from top of the pole. The length of step bolt shall be minimum 150mm and diameter 16mm. Each step bolt should be provided with 2 nuts.

#### **4.0 Wind Velocity**

Pole shall be operational and able to withstand the wind velocity of 180 Km/hr. Suitable allowances shall be made for antennas wave guide/feeder cables and maintenance persons.

#### **5.0 Lightning Arrestor**

Lightning arrestor using lightning rod made of copper, with 16mm diameter and 1200mm length as per IS: 613 (2000) with a spike on one end and threading on the other shall be provided on the top of the pole. Tin coated copper wire IS mark of gauge 50 sq. mm shall be provided from lower of the lightning rod to the lug with a hole provided at 0.5m below the top of the pole. The supply of the material and installation shall be in the scope of the supplier.

#### **6.0 Aviation Warning Lights**

Fixing arrangement for twin type aviation warning lights at the top level shall be provided. Aviation Warning Lamps shall conform to ICAO regulation.

**Note:**

- i.** Screened PVC insulated twin copper wire of size 3/22 (IS Marked) shall be used for connection of aviation warning lamp to the power supply.
- ii.** The aviation warning lamps and Screened PVC insulated twin copper shall be supplied by pole supplier. The detail specification is attached at Chapter-4.

#### **7.0 Antenna mounting fixture**

Antennas- GI pipes, conforming to IS: 1161 (1998) with minimum Yst 220 Mpa with 65 NB medium class, 3.0 metre long for cellular wireless system antenna (6 Nos.); 100 NB medium class, 1.5 metre long for 0.6m to 1.2m diameter microwave antenna (6 Nos.) along with the fixtures/ clamps for mounting should be provided as per details given in the BoM.

#### **8.0 Verticality**

The verticality of pole shall be as per IS: 12843: 1989, Table iii (b).

Note: This shall be checked in the field after the erection of the pole at sites.

#### **9.0 Earthing**

For earthing of the pole, 50x3mm GI strips should be bounded to the lower of the pole and connecting to two plate earth as per drawing. Two numbers of plate earth and one ring earth shall be provided. The maximum value of earth resistance shall be 2.0 ohm. For more details please refer to Chapter-3.

Earthing material shall be supplied by pole suppliers.

## **10.0 Welding**

Welding shall be done as per IS: 9595 (1996). No circumferential weld is permitted to make full length of pole segment. Splice plates/ flange are welded at each end of pole segment with stiffeners as per drawing. There should be only one longitudinal joint to make tube of pole segment.

## **11.0 Marking**

Manufacturer's identity marking and item marking shall be provided on each section by punching & painting for Enabling easy assembly and trace -ability. Smaller elements, on which complete marking detail are not practicable, shall be supplied in suitable packing boxes and each box shall be clear marking details such as name of sites, height of the tower and other details as given above. However, part No. / Item No. shall be marked on all tower elements. The tower supplier shall also provide the tower component manufacturer's identity / source. A plate indicating the manufacturer's identity, year of manufacture, wind velocity and the maximum load capacity of the tower shall be supplied by the manufacturer for display at the bottom of the tower. The top horizontal members of the tower on all the four faces should have center clearly by visibly marked for easy check of vertically.

## **12.0 Painting**

The pole shall be coloured with alternate bands of orange & white or red & white paint as per ICAO recommendations. The Ready mixed Paints, Primer, Enamel etc., used for tower painting, shall be as per the following IS codes:

1. IS 2074 (1992): Ready Mixed Paint, Air Drying, Red Oxide Zinc Chrome, Priming-Specification;
2. IS 2932 (1993): Enamel, Synthetic, Exterior:
  - a. Undercoating
  - b. Finishing – specification;
3. IS 2933 (1975): Enamel  
Exterior:
  - a. Undercoating
  - b. Finishing

## **13.0 Documentation**

Two hard copies and one soft copy of complete documents along with installation details, in English, shall be supplied by the supplier.

#### **14.0 Weight of Pole including Accessories (in tolerance of $\pm 3\%$ )**

- a. Weight of Pole structures, inclusive of all parts of Superstructure excluding the weight of antenna fixtures, Nuts, Bolts, Washers and earth strip are 3,385Kg, 2,876Kg and 2,448Kg for 24 metres, 22 metres and 20 metres respectively.
- b. Weight of cellular wireless system antenna mounting arrangement (per antenna): 25.5Kg.
- c. Weight of microwave antenna mounting arrangement (per antenna): 55Kg (for 0.6 m to 1.2m diameter).
- d. Weight of Nuts, Bolts and Washers: 99.4Kg, 88.5Kg and 79.5Kg for 24 metres, 22 metres and 20 metres respectively.

#### **15.0 Weight of Foundations**

##### **24/22/20 m Pole Foundation**

- a. Weight of steel reinforcement (but excluding RCC) is 1491.096 Kg for all 24m, 22m and 20m poles.
- b. Volumes of RCC M20 grade is 16.94m<sup>3</sup> for all 24, 22 and 20 metres poles foundation. Volumes of PCC M10 grade is 3.0255m<sup>3</sup> for all 24, 22 and 20 metres poles foundations.

#### **16.0 Bill of Material**

The Bill of Material for all Poles is given in Chapter-2.

#### **17.0 Design**

The detailed drawing of the pole shall be as per technical specification No. UTL/GBP/01-01 OCT 2011 of UTL.

##### **Notes:**

1. All the major components of material for pole shall be procured from the IS approved sources and certificate to this effect shall be given by manufacturer.
2. All responsibility for pole erection shall lie with the supplier/erection agency which would follow safety norms as per IS 7205(1974)".
3. All IS standards are subject to revision and the most recent editions of the standards shall be applicable.
4. All unspecified holes in pole members are 17.5mm diameter for 16mm bolts conforming to Class 5.6. All unspecified plates 6 mm thick.
5. Structural steel shall conform to IS 2062 grade-A with minimum yields stress of 2550 kg/ sq. cm.

6. Spring washers are to be used under each nut.
7. Pole accessories include lightning protection system, grounding system (including plate earthing), earth strips and horizontal feeder support, antenna mounting structures,.
8. Angular rotation and twist less than 0.5°.
9. The foundation bolts at the base of pole shall be monolithic with the concrete in the foundation.

**Chapter-2**  
**Bill of Material for Ground Based Pole**

**2.1 Bill of Material for 24 M Ground Based Pole**

Sl. No.	MKD	Description	Length	24M POLE		Drawing No.
			mm.	Nos.	Wt. (kg)	
<b>A.</b>	<b>Pole segment</b>					
	<b>Pole P1</b>					UTL/GBP/24-03
	P1	PIPE OD 167 X 5MM THICK	1985	1	39.7	UTL/GBP/24-03
	CAP	PLATE 167 DIA X 3MM	167 DIA	1	0.5	UTL/GBP/24-03
	F1B	FLANGE OD 374 X ID 71X12MM		1	10.0	UTL/GBP/24-03
		STIFFNER 75X100X8	100	8	3.8	UTL/GBP/24-03
	CLT1	PLATE 100X120X6	100	8	4.5	UTL/GBP/24-03
	<b>Pole P2</b>					UTL/GBP/24-03
	P2	PIPE OD 213 X 5MM THICK	1976	1	50.7	UTL/GBP/24-03
	F2T	FLANGE OD 374 X ID 114X12MM		1	9.4	UTL/GBP/24-03
		STIFFNER 80X100X8	100	8	4.0	UTL/GBP/24-03
	F2B	FLANGE OD 416 X ID 114X12MM		1	11.8	UTL/GBP/24-03
		STIFFNER 100X100X8	100	8	5.0	UTL/GBP/24-03
	<b>Pole P3</b>					UTL/GBP/24-04
	P3	PIPE OD 255 X 6MM THICK	1976	1	72.8	UTL/GBT/24-04
	F3T	FLANGE OD 416 X ID 156X12MM		1	11.0	UTL/GBP/24-04
		STIFFNER 80X100X8	100	8	4.0	UTL/GBP/24-04
	F3B	FLANGE OD 458 X ID 156X12MM		1	13.7	UTL/GBP/24-04
		STIFFNER 100X100X8	100	8	5.0	UTL/GBP/24-04
	<b>Pole P4</b>					UTL/GBP/24-04
	P4	PIPE OD 298 X 8MM THICK	1972	1	112.8	UTL/GBT/24-04
	F4T	FLANGE OD 458 X ID 198X12MM		1	12.6	UTL/GBP/24-04
		STIFFNER 80X100X8	100	8	4.0	UTL/GBP/24-04
	F4B	FLANGE OD 500 X ID 198X16MM		1	20.8	UTL/GBP/24-04
		STIFFNER 100X100X8	100	8	5.0	UTL/GBP/24-04
	<b>Pole P5</b>					UTL/GBP/24-05
	P5	PIPE OD 340 X 8MM	1968	1	128.9	UTL/GBP/24-05

Sl. No.	MKD	Description	Length	24M POLE		Drawing No.
			mm.	Nos.	Wt. (kg)	
		THICK				
	F5T	FLANGE OD 500 X ID 240X16MM		1	14.2	UTL/GBP/24-05
		STIFFNER 80X100X8	100	8	4.0	UTL/GBP/24-05
	F5B	FLANGE OD 543 X ID 240X16MM		1	23.4	UTL/GBP/24-05
		STIFFNER 100X100X8	100	10	6.3	UTL/GBP/24-05
	<b>Pole P6</b>					UTL/GBP/24-05
	P6	PIPE OD 383 X 8MM THICK	1968	1	145.6	UTL/GBP/24-05
	F6T	FLANGE OD 543 X ID 283X16MM		1	21.2	UTL/GBP/24-05
		STIFFNER 80X100X8	100	10	5.0	UTL/GBP/24-05
	F6B	FLANGE OD 585 X ID 283X16MM		1	25.9	UTL/GBP/24-05
		STIFFNER 100X100X8	100	10	6.3	UTL/GBP/24-05
	<b>Pole P7</b>					UTL/GBP/24-06
	P7	PIPE OD 425 X 8MM THICK	1964	1	161.6	UTL/GBP/24-06
	F7T	FLANGE OD 585 X ID 325X16MM		1	23.3	UTL/GBP/24-06
		STIFFNER 80X100X8	100	10	5.0	UTL/GBP/24-06
	F7B	FLANGE OD 627 X ID 325X20MM		1	35.5	UTL/GBP/24-06
		STIFFNER 100X100X8	100	12	7.5	UTL/GBP/24-06
	<b>Pole P8</b>					UTL/GBP/24-06
	P8	PIPE OD 468 X 8MM THICK	1960	1	177.9	UTL/GBP/24-06
	F8T	FLANGE OD 627 X ID 368X20MM		1	31.8	UTL/GBP/24-06
		STIFFNER 80X100X8	100	12	6.0	UTL/GBP/24-06
	F8B	FLANGE OD 670 X ID 368X20MM		1	38.7	UTL/GBP/24-06
		STIFFNER 100X100X8	100	12	7.5	UTL/GBP/24-06
	<b>Pole P9</b>					UTL/GBP/24-07
	P9	PIPE OD 510 X 8MM THICK	1960	1	194.1	UTL/GBP/24-07
	F9T	FLANGE OD 670 X ID 410X20MM		1	34.6	UTL/GBP/24-07
		STIFFNER 80X100X8	100	12	6.0	UTL/GBP/24-07
	F9B	FLANGE OD 712 X ID 410X20MM		1	41.8	UTL/GBP/24-07
		STIFFNER 100X100X8	100	16	10.0	UTL/GBP/24-07
	<b>Pole P10</b>					UTL/GBP/24-07
	P10	PIPE OD 553 X 10MM THICK	1960	1	262.5	UTL/GBP/24-07

Sl. No.	MKD	Description	Length	24M POLE		Drawing No.
			mm.	Nos.	Wt. (kg)	
	F10T	FLANGE OD 712 X ID 453X20MM		1	37.2	UTL/GBP/24-07
		STIFFNER 80X100X8	100	16	8.0	UTL/GBP/24-07
	F10B	FLANGE OD 755 X ID 453X20MM		1	45.0	UTL/GBP/24-07
		STIFFNER 100X100X8	100	16	10.0	UTL/GBP/24-07
	<b>Pole P11</b>					UTL/GBP/24-08
	P11	PIPE OD 595 X 10MM THICK	1960	1	282.8	UTL/GBP/24-08
	F11T	FLANGE OD 755 X ID 495X20MM		1	40.1	UTL/GBP/24-08
		STIFFNER 80X100X8	100	16	8.0	UTL/GBP/24-08
	F11B	FLANGE OD 797 X ID 495X20MM		1	48.1	UTL/GBP/24-08
		STIFFNER 100X100X8	100	20	12.6	UTL/GBP/24-08
	<b>Pole P12</b>					UTL/GBP/24-08
	P12	PIPE OD 637 X 12MM THICK	1960	1	362.5	UTL/GBP/24-08
	F12T	FLANGE OD 797 X ID 537X20MM		1	42.8	UTL/GBP/24-08
		STIFFNER 80X100X8	100	20	10.0	UTL/GBP/24-08
	B24	BASE PLATE 887X887X20 X ID507	887	1	91.8	UTL/GBP/24-09
		STIFFNER 100X100X8	100	16	15.1	UTL/GBP/24-09
<b>B.</b>	<b>Anchor Bolt</b>					
		Plain rod 25 diameter	1400	16	87.4	UTL/GBP/24-09
		Flat 75x75x8	75	16	5.7	UTL/GBP/24-09
<b>C.</b>	<b>Antenna ring</b>					
	RG	RING PIPE NB50M	6283.185	2	64.1	UTL/GBP/24-01
	RSP	SPLICE PLATE 140X140X6	140	8	7.4	UTL/GBP/24-01
	RH1	HOLDING ARM L50x50x6	979	8	35.2	UTL/GBP/24-01
		UCLAMP PLAINROD 16 DIA	220	8	2.8	UTL/GBP/24-01
		BOOM PIPE 65NBM	3000	6	122.4	UTL/GBP/24-01
		UCLAMP PLAINROD 16 DIA	250	24	9.5	UTL/GBP/24-01
		PLATE 150X250X6	150	12	21.2	UTL/GBP/24-01
<b>D.</b>	<b>AMS FOR PARABOLIC ANTENNA</b>					
	CP1	CLAMP FLAT 100X8	900	8	45.2	UTL/GBP/24-01
	CLT2	CLEAT PLATE 80X110X10	110	8	5.5	UTL/GBP/24-01
	RH2	HOLDING ARM L75x75x6	570	8	31.0	UTL/GBP/24-01

Sl. No.	MKD	Description	Length	24M POLE		Drawing No.
			mm.	Nos.	Wt. (kg)	
	D6R	BOOM PIPE 100NBM	1500	4	73.2	UTL/GBP/24-01
		UCLAMP PLAINROD 20 DIA	460	8	9.6	UTL/GBP/24-01
<b>E.</b>	<b>RF CABLE CLAMP</b>					
		BRACKET FLAT 40X5	770	25	30.2	UTL/GBP/24-01
		SUPPORT TEE ANGLE1 50X50X5	300	25	28.5	UTL/GBP/24-01
	CBT	SUPPORT TEE ANGLE2 50X50X5	500	25	47.5	UTL/GBP/24-01
	UCL1	U CLEAT FLAT 50X5X230 LONG	230	50	22.6	UTL/GBP/24-01
<b>F.</b>	<b>STEP BOLT CLEAT</b>					
	UCL1	U CLEAT FLAT 50X5X230 LONG	230	71	32.0	UTL/GBP/24-01
<b>G.</b>	<b>RF CABLE HORIZONTAL BRIDGE</b>					
	CL14L	L50X50X5	5360	2	40.7	UTL/GBP/24-10
	CL14R	L50X50X5	5360	2	40.7	UTL/GBP/24-10
	CLF	FLAT 40X5	380	14	8.5	UTL/GBP/24-10
	Pipe	NB50M	3000	6	91.8	
<b>H.</b>	<b>NUT BOLTS WASHERS</b>					
		<b>BOLTS</b>				
	M12X40			24	1.2	
	M16X40			68	6.3	
	M16X45			24	2.4	
	M16X65	1-2,2-3		16	2.0	
	M16X150	STEP BOLT		71	19.5	
	M20X70	2-3,3-4,4-5,5-6,6-7		36	8.1	
	M20X80	7-8, 8-9, 9-10, 10-11, 11-12		80	19.6	
		<b>NUT</b>				
	M12			24	0.5	
	M16			282	11.5	
	M20			116	8.8	
	M24			32	4.2	
		<b>PLAIN WASHER</b>				
	WP-M12			24	0.3	
	WP-M16			282	6.2	
	WP-M20			116	3.9	
	M24			16	0.5	
		<b>SPRING WASHER</b>				

Sl. No.	MKD	Description	Length	24M POLE		Drawing No.
			mm.	Nos.	Wt. (kg)	
	WS-M12			24	0.1	
	WS-M16			282	2.5	
	WS-M20			116	1.8	

### 2.1.1 Bill of Material for Foundation for 24 M Ground Based Pole.

Sl. No.	Item of work	Nos.	L	B	H/D	Qty	Unit
			m	m	m		
1.	Earth work on excavation	1	5.5	5.5	3.3	<b>99.825</b>	<b>m<sup>3</sup></b>
2.	6" soling on foundation	1	5.5	5.5	0.2	<b>6.05</b>	<b>m<sup>3</sup></b>
3.	PCC 1:3:6	1	5.5	5.5	0.1	<b>3.025</b>	<b>m<sup>3</sup></b>
4.	RCC 1:1.5:3 (M20)						
	On footing	1	5.5	5.5	0.45	13.6125	m <sup>3</sup>
	on pedestal shaft	4	0.55	0.55	2.75	3.3275	m <sup>3</sup>
<b>Total RCC M20</b>						<b>16.94</b>	<b>m<sup>3</sup></b>
5.	Form work						
	On footing	1	22		0.45	9.9	m <sup>2</sup>
	on pedestal shaft	4	2.2		2.75	6.05	m <sup>2</sup>
<b>Total form work</b>						<b>15.95</b>	<b>m<sup>2</sup></b>
6.	Reinforcement steel work						
	on footing						
	main bar 16 DIA	140	5.75	@	1.58	1271.9	kg
	on pedestal shaft						kg
	main bar 25 DIA	12	4.2	@	3.9	196.56	kg
	stirrups 1 8 DIA	17	1.95	@	0.4	13.26	kg
	stirrups 2 8 DIA	17	1.378858	@	0.4	9.376236	kg
<b>Total reinforcement work</b>						<b>1491.096</b>	<b>kg</b>
7.	Earthwork on Backfilling					<b>73.81</b>	<b>m<sup>3</sup></b>

## 2.2 Bill of Material for 22 M Ground Based Pole

Sl. No.	MKD	Description	Length	22M POLE		Drawing No.
			mm.	Nos.	Wt. (kg)	
<b>A.</b>	<b>Pole segment</b>					
	<b>Pole P1</b>					UTL/GBP/22-03
	P1	PIPE OD 167 X 5MM THICK	1985	1	39.7	UTL/GBP/22-03
	CAP	PLATE 167 DIA X 3MM	167 DIA	1	0.5	UTL/GBP/22-03
	F1B	FLANGE OD 374 X ID 71X12MM		1	10.0	UTL/GBP/22-03
		STIFFNER 75X100X8	100	8	3.8	UTL/GBP/22-03
	CLT1	PLATE 100X120X6	100	8	4.5	UTL/GBP/22-03
	<b>Pole P2</b>					UTL/GBP/22-03
	P2	PIPE OD 213 X 5MM THICK	1976	1	50.7	UTL/GBP/22-03
	F2T	FLANGE OD 374 X ID 114X12MM		1	9.4	UTL/GBP/22-03
		STIFFNER 80X100X8	100	8	4.0	UTL/GBP/22-03
	F2B	FLANGE OD 416 X ID 114X12MM		1	11.8	UTL/GBP/22-03
		STIFFNER 100X100X8	100	8	5.0	UTL/GBP/22-03
	<b>Pole P3</b>					UTL/GBP/22-04
	P3	PIPE OD 255 X 6MM THICK	1976	1	72.8	UTL/GBP/22-04
	F3T	FLANGE OD 416 X ID 156X12MM		1	11.0	UTL/GBP/22-04
		STIFFNER 80X100X8	100	8	4.0	UTL/GBP/22-04
	F3B	FLANGE OD 458 X ID 156X12MM		1	13.7	UTL/GBP/22-04
		STIFFNER 100X100X8	100	8	5.0	UTL/GBP/22-04
	<b>Pole P4</b>					UTL/GBP/22-04
	P4	PIPE OD 298 X 8MM THICK	1972	1	112.8	UTL/GBP/22-14
	F4T	FLANGE OD 458 X ID 198X12MM		1	12.6	UTL/GBP/22-04
		STIFFNER 80X100X8	100	8	4.0	UTL/GBP/22-04
	F4B	FLANGE OD 500 X ID 198X16MM		1	20.8	UTL/GBP/22-04
		STIFFNER 100X100X8	100	8	5.0	UTL/GBP/22-04
	<b>Pole P5</b>					UTL/GBP/22-05
	P5	PIPE OD 340 X 8MM THICK	1968	1	128.9	UTL/GBP/22-05
	F5T	FLANGE OD 500 X ID 240X16MM		1	14.2	UTL/GBP/22-05
		STIFFNER 80X100X8	100	8	4.0	UTL/GBP/22-05

Sl. No.	MKD	Description	Length	22M POLE		Drawing No.
			mm.	Nos.	Wt. (kg)	
	F5B	FLANGE OD 543 X ID 240X16MM		1	23.4	UTL/GBP/22-05
		STIFFNER 100X100X8	100	10	6.3	UTL/GBP/22-05
	<b>Pole P6</b>					UTL/GBP/22-05
	P6	PIPE OD 383 X 8MM THICK	1968	1	145.6	UTL/GBP/22-05
	F6T	FLANGE OD 543 X ID 283X16MM		1	21.2	UTL/GBP/22-05
		STIFFNER 80X100X8	100	10	5.0	UTL/GBP/22-05
	F6B	FLANGE OD 585 X ID 283X16MM		1	25.9	UTL/GBP/22-05
		STIFFNER 100X100X8	100	10	6.3	UTL/GBP/22-05
	<b>Pole P7</b>					UTL/GBP/22-06
	P7	PIPE OD 425 X 8MM THICK	1964	1	161.6	UTL/GBP/22-06
	F7T	FLANGE OD 585 X ID 325X16MM		1	23.3	UTL/GBP/22-06
		STIFFNER 80X100X8	100	10	5.0	UTL/GBP/22-06
	F7B	FLANGE OD 627 X ID 325X20MM		1	35.5	UTL/GBP/22-06
		STIFFNER 100X100X8	100	12	7.5	UTL/GBP/22-06
	<b>Pole P8</b>					UTL/GBP/22-06
	P8	PIPE OD 468 X 8MM THICK	1960	1	177.9	UTL/GBP/22-06
	F8T	FLANGE OD 627 X ID 368X20MM		1	31.8	UTL/GBP/22-06
		STIFFNER 80X100X8	100	12	6.0	UTL/GBP/22-06
	F8B	FLANGE OD 670 X ID 368X20MM		1	38.7	UTL/GBP/22-06
		STIFFNER 100X100X8	100	12	7.5	UTL/GBP/22-06
	<b>Pole P9</b>					UTL/GBP/22-07
	P9	PIPE OD 510 X 8MM THICK	1960	1	194.1	UTL/GBP/22-07
	F9T	FLANGE OD 670 X ID 410X20MM		1	34.6	UTL/GBP/22-07
		STIFFNER 80X100X8	100	12	6.0	UTL/GBP/22-07
	F9B	FLANGE OD 712 X ID 410X20MM		1	41.8	UTL/GBP/22-07
		STIFFNER 100X100X8	100	16	10.0	UTL/GBP/22-07
	<b>Pole P10</b>					UTL/GBP/22-07
	P10	PIPE OD 553 X 10MM THICK	1960	1	262.5	UTL/GBP/22-07
	F10T	FLANGE OD 712 X ID 453X20MM		1	37.2	UTL/GBP/22-07
		STIFFNER 80X100X8	100	16	8.0	UTL/GBP/22-07
	F10B	FLANGE OD 755 X ID		1	45.0	UTL/GBP/22-07

Sl. No.	MKD	Description	Length	22M POLE		Drawing No.
			mm.	Nos.	Wt. (kg)	
		453X20MM				
		STIFFNER 100X100X8	100	16	10.0	UTL/GBP/22-07
	<b>Pole P11</b>					UTL/GBP/22-08
	P11	PIPE OD 595 X 10MM THICK	1960	1	282.8	UTL/GBP/22-08
	F11T	FLANGE OD 755 X ID 495X20MM		1	40.1	UTL/GBP/22-08
		STIFFNER 80X100X8	100	16	8.0	UTL/GBP/22-08
	B22	BASE PLATE 845X845X20 X ID465	845	1	85.4	UTL/GBP/22-09
		STIFFNER 100X100X8	100	14	13.2	UTL/GBP/22-09
<b>B.</b>	<b>Anchor Bolt</b>					
		Plain rod 25 dia	1400	14	76.4	UTL/GBP/22-09
		Flat 75x75x8	75	14	4.9	UTL/GBP/22-09
<b>C.</b>	<b>Antenna ring</b>					
	RG	RING PIPE NB50M	6283.185	2	64.1	UTL/GBP/22-01
	RSP	SPLICE PLATE 140X140X6	140	8	7.4	UTL/GBP/22-01
	RH1	HOLDING ARM L50x50x6	979	8	35.2	UTL/GBP/22-01
		UCLAMP PLAINROD 16 DIA	220	8	2.8	UTL/GBP/22-01
		BOOM PIPE 65NBM	3000	6	122.4	UTL/GBP/22-01
		UCLAMP PLAINROD 16 DIA	250	24	9.5	UTL/GBP/22-01
		PLATE 150X250X6	150	12	21.2	UTL/GBP/22-01
<b>D.</b>	<b>AMS FOR PARABOLIC ANTENNA</b>					
	CP1	CLAMP FLAT 100X8	900	8	45.2	UTL/GBP/22-01
	CLT2	CLEAT PLATE 80X110X10	110	8	5.5	UTL/GBP/22-01
	RH2	HOLDING ARM L75x75x6	570	8	31.0	UTL/GBP/22-01
	D6R	BOOM PIPE 100NBM	1500	4	73.2	UTL/GBP/22-01
		UCLAMP PLAINROD 20 DIA	460	8	9.6	UTL/GBP/22-01
<b>E.</b>	<b>RF CABLE CLAMP</b>					
		BRACKET FLAT 40X5	770	23	27.8	UTL/GBP/22-01
		SUPPORT TEE ANGLE1 50X50X5	300	23	26.2	UTL/GBP/22-01
	CBT	SUPPORT TEE ANGLE2 50X50X5	500	23	43.7	UTL/GBP/22-01
	UCL1	U CLEAT FLAT 50X5X230 LONG	230	46	20.8	UTL/GBP/22-01
<b>F.</b>	<b>STEP BOLT CLEAT</b>					

Sl. No.	MKD	Description	Length	22M POLE		Drawing No.
			mm.	Nos.	Wt. (kg)	
	UCL1	U CLEAT FLAT 50X5X230 LONG	230	64	28.9	UTL/GBP/22-01
<b>G.</b>	<b>RF CABLE HORIZONTAL BRIDGE</b>					
	CL14L	L50X50X5	5360	2	40.7	UTL/GBP/22-10
	CL14R	L50X50X5	5360	2	40.7	UTL/GBP/22-10
	CLF	FLAT 40X5	380	14	8.5	UTL/GBP/22-10
	Pipe	NB50M	3000	6	91.8	
<b>H.</b>	<b>NUT BOLTS WASHERS</b>					
		<b>BOLTS</b>				
	M12X40			24	1.2	
	M16X40			68	6.3	
	M16X45			24	2.4	
	M16X65	1-2,2-3		16	2.0	
	M16X150	STEP BOLT		64	17.6	
	M20X70	2-3,3-4,4-5,5-6,6-7		36	8.1	
	M20X80	7-8, 8-9, 9-10, 10-11, 11-12		60	14.7	
		<b>NUT</b>				
	M12			24	0.5	
	M16			268	11	
	M20			96	7.3	
	M24			28	3.7	
		<b>PLAIN WASHER</b>				
	WP-M12			24	0.3	
	WP-M16			268	5.9	
	WP-M20			96	3.3	
	M24			14	0.5	
		<b>SPRING WASHER</b>				
	WS-M12			24	0.1	
	WS-M16			268	2.4	
	WS-M20			96	1.5	

### 2.2.1 Bill of Material for Foundation for 22 M Ground Based Pole.

Sl. No.	Item of work	Nos.	L	B	H/D	Qty	Unit
			m	m	m		
1.	Earth work on excavation	1	5.5	5.5	3.3	<b>99.825</b>	<b>m<sup>3</sup></b>
2.	6" soling on foundation	1	5.5	5.5	0.2	<b>6.05</b>	<b>m<sup>3</sup></b>
3.	PCC 1:3:6	1	5.5	5.5	0.1	<b>3.025</b>	<b>m<sup>3</sup></b>
4.	RCC 1:1.5:3 (M20)						
	On footing	1	5.5	5.5	0.45	13.6125	m <sup>3</sup>
	on pedestal shaft	4	0.55	0.55	2.75	3.3275	m <sup>3</sup>
<b>Total RCC M20</b>						<b>16.94</b>	<b>m<sup>3</sup></b>
5.	Form work						
	On footing	1	22		0.45	9.9	m <sup>2</sup>
	on pedestal shaft	4	2.2		2.75	6.05	m <sup>2</sup>
<b>Total form work</b>						<b>15.95</b>	<b>m<sup>2</sup></b>
6.	Reinforcement steel work						
	on footing						
	main bar 16 DIA	140	5.75	@	1.58	1271.9	kg
	on pedestal shaft						kg
	main bar 25 DIA	12	4.2	@	3.9	196.56	kg
	stirrups1 8 DIA	17	1.95	@	0.4	13.26	kg
	stirrups2 8 DIA	17	1.378858	@	0.4	9.376236	kg
<b>Total reinforcement work</b>						<b>1491.096</b>	<b>kg</b>
7.	Earthwork on Backfilling					<b>73.81</b>	<b>m<sup>3</sup></b>

### 2.3 Bill of Material for 20 M Ground Based Pole

Sl. No.	MKD	Description	Length	20M POLE		Drawing No.
			mm.	Nos.	Wt. (kg)	
<b>A.</b>	<b>Pole segment</b>					
	<b>Pole P1</b>					UTL/GBP/20-03
	P1	PIPE OD 167 X 5MM THICK	1985	1	39.7	UTL/GBP/20-03
	CAP	PLATE 167 DIA X 3MM	167 DIA	1	0.5	UTL/GBP/20-03
	F1B	FLANGE OD 374 X ID 71X12MM		1	10.0	UTL/GBP/20-03
		STIFFNER 75X100X8	100	8	3.8	UTL/GBP/20-03
	CLT1	PLATE 100X120X6	100	8	4.5	UTL/GBP/20-03
	<b>Pole P2</b>					UTL/GBP/20-03
	P2	PIPE OD 213 X 5MM THICK	1976	1	50.7	UTL/GBP/20-03
	F2T	FLANGE OD 374 X ID 114X12MM		1	9.4	UTL/GBP/20-03
		STIFFNER 80X100X8	100	8	4.0	UTL/GBP/20-03
	F2B	FLANGE OD 416 X ID 114X12MM		1	11.8	UTL/GBP/20-03
		STIFFNER 100X100X8	100	8	5.0	UTL/GBP/20-03
	<b>Pole P3</b>					UTL/GBP/20-04
	P3	PIPE OD 255 X 6MM THICK	1976	1	72.8	UTL/GBP/20-04
	F3T	FLANGE OD 416 X ID 156X12MM		1	11.0	UTL/GBP/20-04
		STIFFNER 80X100X8	100	8	4.0	UTL/GBP/20-04
	F3B	FLANGE OD 458 X ID 156X12MM		1	13.7	UTL/GBP/20-04
		STIFFNER 100X100X8	100	8	5.0	UTL/GBP/20-04
	<b>Pole P4</b>					UTL/GBP/20-04
	P4	PIPE OD 298 X 8MM THICK	1972	1	112.8	UTL/GBP/20-14
	F4T	FLANGE OD 458 X ID 198X12MM		1	12.6	UTL/GBP/20-04
		STIFFNER 80X100X8	100	8	4.0	UTL/GBP/20-04
	F4B	FLANGE OD 500 X ID 198X16MM		1	20.8	UTL/GBP/20-04
		STIFFNER 100X100X8	100	8	5.0	UTL/GBP/20-04
	<b>Pole P5</b>					UTL/GBP/20-05
	P5	PIPE OD 340 X 8MM THICK	1968	1	128.9	UTL/GBP/20-05
	F5T	FLANGE OD 500 X ID 240X16MM		1	14.2	UTL/GBP/20-05
		STIFFNER 80X100X8	100	8	4.0	UTL/GBP/20-05
	F5B	FLANGE OD 543 X ID 240X16MM		1	23.4	UTL/GBP/20-05

Sl. No.	MKD	Description	Length	20M POLE		Drawing No.
			mm.	Nos.	Wt. (kg)	
		STIFFNER 100X100X8	100	10	6.3	UTL/GBP/20-05
	<b>Pole P6</b>					UTL/GBP/20-05
	P6	PIPE OD 383 X 8MM THICK	1968	1	145.6	UTL/GBP/20-05
	F6T	FLANGE OD 543 X ID 283X16MM		1	21.2	UTL/GBP/20-05
		STIFFNER 80X100X8	100	10	5.0	UTL/GBP/20-05
	F6B	FLANGE OD 585 X ID 283X16MM		1	25.9	UTL/GBP/20-05
		STIFFNER 100X100X8	100	10	6.3	UTL/GBP/20-05
	<b>Pole P7</b>					UTL/GBP/20-06
	P7	PIPE OD 425 X 8MM THICK	1964	1	161.6	UTL/GBP/20-06
	F7T	FLANGE OD 585 X ID 325X16MM		1	23.3	UTL/GBP/20-06
		STIFFNER 80X100X8	100	10	5.0	UTL/GBP/20-06
	F7B	FLANGE OD 627 X ID 325X20MM		1	35.5	UTL/GBP/20-06
		STIFFNER 100X100X8	100	12	7.5	UTL/GBP/20-06
	<b>Pole P8</b>					UTL/GBP/20-06
	P8	PIPE OD 468 X 8MM THICK	1960	1	177.9	UTL/GBP/20-06
	F8T	FLANGE OD 627 X ID 368X20MM		1	31.8	UTL/GBP/20-06
		STIFFNER 80X100X8	100	12	6.0	UTL/GBP/20-06
	F8B	FLANGE OD 670 X ID 368X20MM		1	38.7	UTL/GBP/20-06
		STIFFNER 100X100X8	100	12	7.5	UTL/GBP/20-06
	<b>Pole P9</b>					UTL/GBP/20-07
	P9	PIPE OD 510 X 8MM THICK	1960	1	194.1	UTL/GBP/20-07
	F9T	FLANGE OD 670 X ID 410X20MM		1	34.6	UTL/GBP/20-07
		STIFFNER 80X100X8	100	12	6.0	UTL/GBP/20-07
	F9B	FLANGE OD 712 X ID 410X20MM		1	41.8	UTL/GBP/20-07
		STIFFNER 100X100X8	100	16	10.0	UTL/GBP/20-07
	<b>Pole P10</b>					UTL/GBP/20-08
	P10	PIPE OD 553 X 10MM THICK	1960	1	262.5	UTL/GBP/20-08
	F10T	FLANGE OD 712 X ID 453X20MM		1	37.2	UTL/GBP/20-08
		STIFFNER 80X100X8	100	16	8.0	UTL/GBP/20-08
	B20	BASE PLATE 803X803X20 X ID423	803	1	79.2	UTL/GBP/20-08
		STIFFNER 100X100X8	100	12	11.3	UTL/GBP/20-08
<b>B.</b>	<b>Anchor Bolt</b>					
		Plain rod 25 dia	1400	12	65.5	UTL/GBP/20-09

Sl. No.	MKD	Description	Length	20M POLE		Drawing No.
			mm.	Nos.	Wt. (kg)	
		Flat 75x75x8	75	12	4.2	UTL/GBP/20-09
<b>C.</b>	<b>Antenna ring</b>					
	RG	RING PIPE NB50M	6283.185	2	64.1	UTL/GBP/20-01
	RSP	SPLICE PLATE 140X140X6	140	8	7.4	UTL/GBP/20-01
	RH1	HOLDING ARM L50x50x6	979	8	35.2	UTL/GBP/20-01
		UCLAMP PLAINROD 16 DIA	220	8	2.8	UTL/GBP/20-01
		BOOM PIPE 65NBM	3000	6	122.4	UTL/GBP/20-01
		UCLAMP PLAINROD 16 DIA	250	24	9.5	UTL/GBP/20-01
		PLATE 150X250X6	150	12	21.2	UTL/GBP/20-01
<b>D.</b>	<b>AMS FOR PARABOLIC ANTENNA</b>					
	CP1	CLAMP FLAT 100X8	900	8	45.2	UTL/GBP/20-01
	CLT2	CLEAT PLATE 80X110X10	110	8	5.5	UTL/GBP/20-01
	RH2	HOLDING ARM L75x75x6	570	8	31.0	UTL/GBP/20-01
	D6R	BOOM PIPE 100NBM	1500	4	73.2	UTL/GBP/20-01
		UCLAMP PLAINROD 20 DIA	460	8	9.6	UTL/GBP/20-01
<b>E.</b>	<b>RF CABLE CLAMP</b>					
		BRACKET FLAT 40X5	770	21	25.4	UTL/GBP/20-01
		SUPPORT TEE ANGLE1 50X50X5	300	21	23.9	UTL/GBP/20-01
	CBT	SUPPORT TEE ANGLE2 50X50X5	500	21	39.9	UTL/GBP/20-01
	UCL1	U CLEAT FLAT 50X5X230 LONG	230	21	9.5	UTL/GBP/20-01
<b>F.</b>	<b>STEP BOLT CLEAT</b>					
	UCL1	U CLEAT FLAT 50X5X230 LONG	230	58	26.2	UTL/GBP/20-01
<b>G.</b>	<b>RF CABLE HORIZONTAL BRIDGE</b>					
	CL14L	L50X50X5	5360	2	40.7	UTL/GBP/20-10
	CL14R	L50X50X5	5360	2	40.7	UTL/GBP/20-10
	CLF	FLAT 40X5	380	14	8.5	UTL/GBP/20-10
	Pipe	NB50M	3000	6	91.8	
<b>H.</b>	<b>NUT BOLTS WASHERS</b>					
		<b>BOLTS</b>				
	M12X40			24	1.2	
	M16X40			68	6.3	

Sl. No.	MKD	Description	Length	20M POLE		Drawing No.
			mm.	Nos.	Wt. (kg)	
	M16X45			24	2.4	
	M16X65	1-2,2-3		16	2.0	
	M16X150	STEP BOLT		58	16.0	
	M20X70	2-3,3-4,4-5,5-6,6-7		36	8.1	
	M20X80	7-8, 8-9, 9-10, 10-11, 11-12		44	10.8	
		<b>NUT</b>				
	M12			24	0.5	
	M16			256	10.5	
	M20			80	6.1	
	M24			24	3.2	
		<b>PLAIN WASHER</b>				
	WP-M12			24	0.3	
	WP-M16			256	5.6	
	WP-M20			80	2.7	
	M24			12	0.4	
		<b>SPRING WASHER</b>				
	WS-M12			24	0.1	
	WS-M16			256	2.3	
	WS-M20			80	1.2	

### 2.3.1 Bill of Material for Foundation for 20 Metres Roof Top Tower

Sl. No.	Item of work	Nos.	L	B	H/D	Qty	Unit
			m	m	m		
1.	Earth work on excavation	1	5.5	5.5	3.3	<b>99.825</b>	<b>m<sup>3</sup></b>
2.	6" soling on foundation	1	5.5	5.5	0.2	<b>6.05</b>	<b>m<sup>3</sup></b>
3.	PCC 1:3:6	1	5.5	5.5	0.1	<b>3.025</b>	<b>m<sup>3</sup></b>
4.	RCC 1:1.5:3 (M20)						
	On footing	1	5.5	5.5	0.45	13.6125	m <sup>3</sup>
	on pedestal shaft	4	0.55	0.55	2.75	3.3275	m <sup>3</sup>
<b>Total RCC M20</b>						<b>16.94</b>	<b>m<sup>3</sup></b>
5.	Form work						
	On footing	1	22		0.45	9.9	m <sup>2</sup>
	on pedestal shaft	4	2.2		2.75	6.05	m <sup>2</sup>
<b>Total form work</b>						<b>15.95</b>	<b>m<sup>2</sup></b>
6.	Reinforcement steel work						
	on footing						
	main bar 16 DIA	140	5.75	@	1.58	1271.9	kg
	on pedestal shaft						kg
	main bar 25 DIA	12	4.2	@	3.9	196.56	kg
	stirrups1 8 DIA	17	1.95	@	0.4	13.26	kg
	stirrups2 8 DIA	17	1.378858	@	0.4	9.376236	kg
<b>Total reinforcement work</b>						<b>1491.096</b>	<b>kg</b>
7.	Earthwork on Backfilling					<b>73.81</b>	<b>m<sup>3</sup></b>

### Chapter-3

## Specifications for Earthing System & Lightning Arrestor

### Plate Earth

#### (Layout & interconnection)

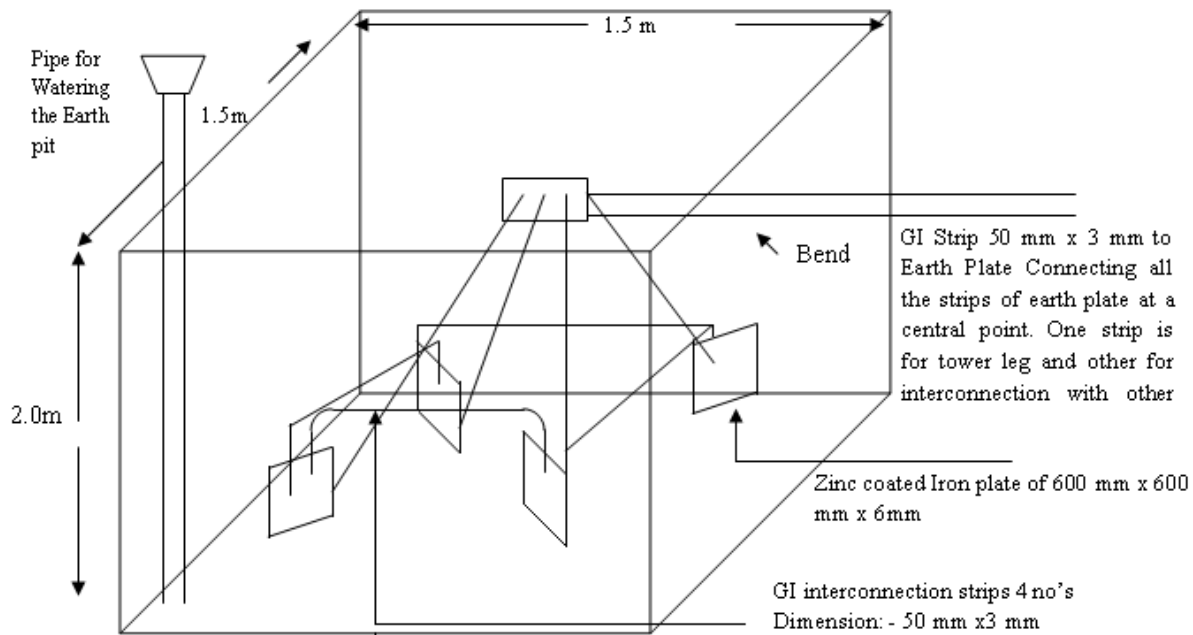

(Diagram not to Scale)

**Figure – 1**

#### Notes:

- GI Plates and Strips are connected by GI nuts and Bolts to prevent ingress of moisture and soil. The joint is made watertight by covering with bitumen.
- The bends in GI strips should not be sharp but within radius of 1 meter as shown in figure 1.
- After the plate earthing electrode is placed in position and all the interconnection made, the pit shall be filled up with fine ash and/or finely sieved good quality soil, which shall be rammed in layers so that it is compact and cohesive.
- Chemical treatment of earth using salts etc. are not recommended as the chemical treatment does not last long and needs to be checked periodically.
- Earth conductor should not be encircled with metal clamps while taking it along the wall. This is essential to eliminate the high inductive reactance that will impede the flow of surge current along the conductor in case of lightning.

- f. Earthing conductor shall not pass through any metallic conduit or pipe as this will increase surge impedance.

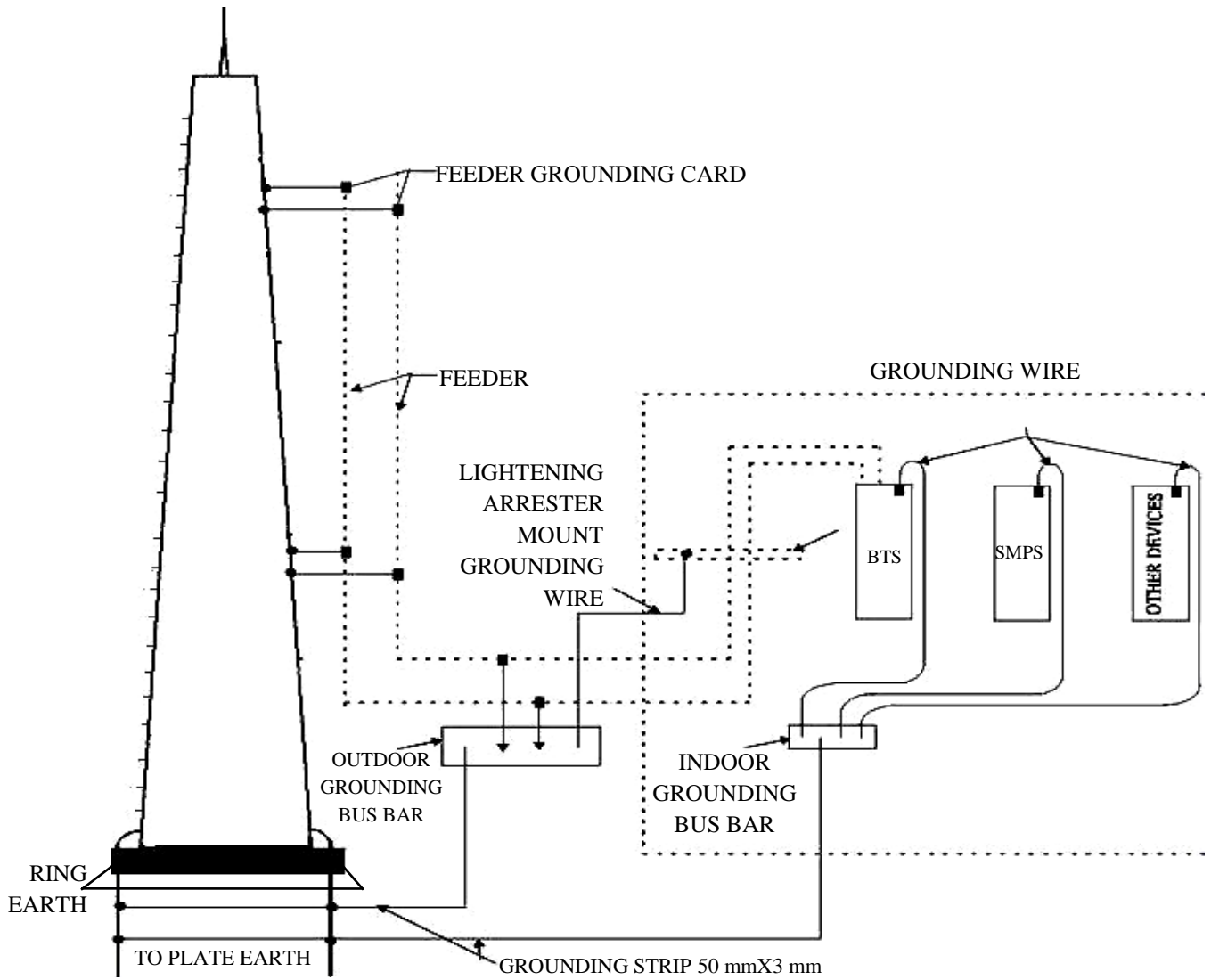

**Figure-2**  
**Earthing arrangement using Outdoor Grounding Bus bar and Indoor Grounding Bus bar**

- 3.1** The bidder shall provide one ring earthing and two numbers of GI plate earthing (one for Electrical and other for equipment) located at least 3 meter apart and should be connected by 50mmx3mm GI strip for maintaining common potential (Figure-2). Each plate earth system shall have ohmic value  $\leq 2\Omega$ .
- 3.2** Each earth plate (Figure-1) shall include excavation of pit of size 1500x1500x2000mm depth and placing four numbers of G I plates of size 300x300x6 mm thick vertically at diagonally opposite ends in the excavated pit and inter connecting the plates with 4 Nos. of 50x3mm G I strips with 2 Nos. of G I bolts and nuts of 10mm diameter at each connection and covering the joints with bitumen, placing G I pipe of 50mm internal diameter (B Class) and 2000mm length at the center of the plate grid for watering and filling the pit with fine ash and / or finally sieved good quality soil including ramming in 20 cm layers etc complete and cover the pit with 750x750x50mm thick precast reinforced cement concrete slab having 100mm diameter hole at the centre to pass the GI pipe and construct a chamber of internal size not less than 280x280x250mm with half brick wall including fixing CI manhole cover of size 300x300mm of weight not less than 7.20 Kg. (cover & frame) and plastering the chamber on all sides with cement mortar 1:4 of 12mm thick (1 cement : 4 fine sand) and including disposal of surplus excavated earth if any.
- 3.3** The bidder shall terminate separate earth strips from the two earth pits up to indoor and outdoor grounding bus bar mounted on the wall of building/shelter (i.e. one earth strip from first pit to indoor grounding bus bar and another from second earth pit to outdoor grounding bus bar) as per figure-2.
- 3.4** The bidder shall provide ring earth by providing GI Strip of size 50mm x 3 mm around the pole in the trench and minimum one meter away from the pole by digging a trench 50 cm. wide and 150 cm. deep. The depth should not be less than 90 cm, in any case (for rocky soil). To get the resistance of 2 ohms if any extra treatment of the soil is required the same has to be done by the supplier without any extra cost.
- 3.5** The bidder shall provide four GI strips of size 50x3 mm, one end connected to the legs at the bottom of poles with GI bolts and nuts [with lead sheath in between] and the other end shall be connected to the ring earth with G I bolts and nuts [with lead sheath in between] without any sharp bends using necessary clamps and screws.
- 3.6** The bidder shall provide GI bus bar of 50 x 3 mm or 50sq. mm Copper cable (PVC insulated) connected to the lightning conductor and to the ring earth with 2 Nos. of 10 mm diameter GI nuts & bolts [with lead sheath in between] at each connection. The bus bar shall be drawn through heat shrink sleeve and shall be shrunk properly. The bus bar/cable shall be clamped to the poles walls at uniform interval of 1.5 M. using proper clamps and insulators such that the bus bar shall be well insulated from the poles/building walls completely.

\*\*\*

**Chapter-4**  
**Technical Specifications for Aviation Warning Light**

1. **No. of LEDS** : at least 170.
2. **Maximum forward current**: 45 mA
3. **Input Voltage Variability**: Shall withstand fluctuation of  $\pm 25\%$
4. **Power Consumption**: 5 W to 15 W (48V DC Supply)
5. **PIV protection**: LEDs internally protected against rev. voltage up to 1 KV
6. **Insulation Resistance**:  $>200 \text{ M}\Omega$
7. **Dielectric Strength**:  $\geq 2.5 \text{ KV}$
8. **Earthing**: Terminal shall be provided inside body
9. **Body Material**: Aluminium body with powder coating
10. **Dome Material**: Polycarbonate unbreakable red dome
11. **Cable entry**: PG11 cable gland
12. **Photo sensor**: Inbuilt photosensor for automatic operation
13. **Illuminance**:  $\geq 3000 \text{ lux}$
14. **No. of Circuits**: Multiple Circuits provided for maximum reliability.
15. **Type of LEDS**: Ultra high glow LEDs
16. **Warranty**: 36 months

**Note:** Screened PVC insulated twin copper wire of size 3/22 IS Mark shall be provided by Supplier. The length of Wire may be considered as 30m on an average for each Site.

**Chapter-5**  
**Key Diagrams**